

26

by Rina Mardiati

Submission date: 27-Apr-2023 01:20PM (UTC+0700)

Submission ID: 2076941072

File name: 080709.pdf (439.68K)

Word count: 3530

Character count: 16631

Prototype of Robot Movement Navigation System Using Pixy Camera (CMUCAM 5)

Muhammad Fasha Aqillah
Department of Electrical Engineering
UIN Sunan Gunung Djati Bandung
Bandung, Indonesia
fashaqaqillah12@gmail.com

Rina Mardiaty
Department of Electrical Engineering
UIN Sunan Gunung Djati Bandung
Bandung, Indonesia
r_mardiaty@uinsgd.ac.id

Aan Eko Setiawan
Department of Electrical Engineering
Telkom University
Bandung, Indonesia
aaneko37@gmail.com

Abstract—Technological advances support the development of tools used in the industrial sector, one of which is the Automated Guided Vehicle (AGV). AGV can be used to deliver goods automatically. This AGV can be made using visual sensors, one of which is the Pixy camera. This AGV robot can be used to follow the motion of objects. In addition to the Pixy camera as a visual sensor, the Arduino Mega 2560 is also used as a microcontroller, and the L298N motor driver shield with two DC motors. The distance and speed of the robot are also determined so that it can move in the direction the object is going. Manoeuvring is needed on a robot with better sharpness and ability, so Mamdani fuzzy logic control is used as a method. Tests are carried out using the Turn value or Position and Area or the distance between the camera sensor and the object. The experimental simulation was carried out with a case study of Turn value of 0.6 and Area of 6000. Testing was carried out using simulation software and Arduino IDE which were then calculated manually for comparison. The results obtained in testing with the simulation software are 20.80 for the right DC motor and 85.60 for the left DC motor, with the Arduino IDE software the values are 21.11 for the right DC motor and 85.20 for the left DC motor, and the manual calculation produces a value of 21.09 for the right DC motor and 85.04 for the left DC motor. From the resulting data, from the error rate is 98.51% for the right DC motor and 99.53% for the left DC motor.

Keywords—Automated Guided Vehicle, Pixy camera, Arduino Mega 2560, fuzzy logic control Mamdani

I. INTRODUCTION

Robot is one of the tools made with the aim of helping human work and developing along with the times. In industry 4.0, robots are also used in the industrial sector with various functions. Robot is a mechanical system that has a function motion analogous to the locomotion function of living organisms, or a combination of many motions function with intelligent function, which can perform physical tasks, using human supervision and control, or using programs previously defined [1]. In the industrial sector, AGV is one of the existing developments [2]. AGV could be deploy with many kinds of sensor. Mostly, AGV uses camera sensor for their movement. Furthermore, camera sensor could be implemented to make the AGV as a human following robot [3] [4].

One of the important role to build AGV is how to determine a proper method for the navigation system. The navigation system will be related with the movement of robot. The navigation methods were very varied. Several researches has been developed the navigation system based on mathematical approach [5], markov model [6] [7]. Fuzzy logic [8] [9], camera sensor, etc. The use of fuzzy is also intended so that the robot can move with good abilities, such as movement for more accurate curvature and sharpness as shown in Antonelli's research on fuzzy logic based approach for mobile robot path tracking [10].

In this study, we use camera sensor Pixy camera, which is a vision sensor that can detect certain patterns on the target object [11] [12]. The microcontroller used were Arduino Mega 2560 and Motor Driver shield L298N as a DC motor drive [13] [14]. Fuzzy logic control is one method that can be used to control several variables so that the output obtained is as needed [15]. In this study, before doing some experiment, the intended object must be introduced to the vision sensor used. Recognition is done by detecting an object (green color is used) on the Pixy camera. The camera sensor that detects the object will send a signal to the microcontroller which then gives a command to the DC motor to move in the direction or away from the specified object. The signal sent (input) is in the form of Turn (position) and Area (distance) values from the object used, so that the robot will move to follow the position or movement of the object.

II. THE PROPOSED SYSTEM

A. Block Diagram System

The prototype of robot movement navigation system using Pixy camera (CMUCAM 5) uses three system parts, namely: input, process, and output. In the input process, a Pixy camera is used which is placed on the front to identify the intended object. In this research, a closed loop control system is used. In this control system there is feedback in the form of input values that are used and then become outputs. When this value is obtained, the robot will move and the output value (Turn and Area) will change, so that it is used as feedback or the input value back for the next robot movement, can be seen in Fig. 1.

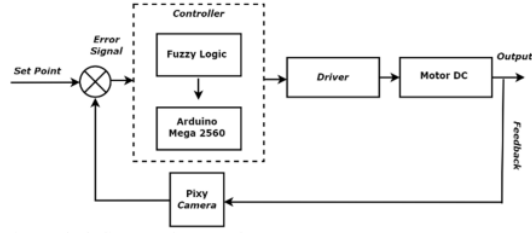

Fig. 1. Block diagram of proposed system.

The navigation system that is carried out is by recognizing certain objects with the vision sensor used and then using the fuzzy logic control Mamdani method as the basic method.

- In the input section, a colored object (green) and a vision sensor (Pixy camera) are used. An object introduction is made to the vision sensor used, this is intended so that the sensor can recognize and move according to the direction of the intended object. The object (green color) in this section as the set point.
- In the process section, Arduino Mega 2560 is used as a microcontroller and fuzzy logic control as a method. The use of fuzzy logic control is intended so that the movement of the robot can be carried out in a subtler way.
- The output section is the output generated from the previous circuit, in which the Arduino Mega 2560 has received input from the Pixy camera and sent commands to the two DC motors used. The feedback in this section means the output from the result become an input again. The output is the Turn and Area (from Pixy camera) from the object movement.

B. Hardware Design

In designing a prototype of a robot movement navigation system using a pixy camera, several supporting components are needed, such as sensors, microcontrollers, and voltage sources. Some of these components can be seen in Table I.

From the various components used, a schematic is made before designing. It can be seen in Fig. 2, the circuit connects the Arduino Mega 2560 with other supporting components, and also uses a battery (Lipo) as a power source (power) for the robot.

TABLE I. COMPONENT

No	Component	
	Name	Lots
1	2 WD Smart Car Chassis for Arduino	1
2	Arduino Mega 2560	1
3	Pixy Camera (CMUCam5)	1
4	Battery Lippo 11 Volt	1
5	Motor Drivershield L298N	1
6	Motor DC	2
7	Cable	15

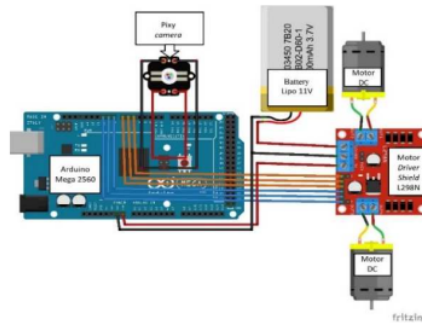

Fig. 2. Schematic system.

C. Software Design

1. Fuzzy Logic Control

The modeling used in the software consists of two inputs and two outputs. The variables used in the input are Turn and Area, turn which means the position of the intended object, and Area which means the area of the object that is read by the sensor or distance between object and robot. The two inputs were obtained from the use of the Pixy camera which was placed on the front of the robot. The output section consists of VR and VL, both of which are variables used to regulate the speed of the DC motor motion.

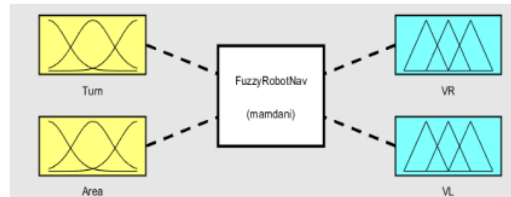

Fig. 3. Fuzzy logic design.

Based on the existing variables, linguistic terms are used to facilitate the discussion of the control system designed in this study. Table II and III shows the input linguistic term used.

TABLE II. LINGUISTIC TERM OF TURN

Linguistic Term of Turn	
Position	Linguistic Term
[-1 -1 -0.5 -0.25]	Left
[0.5 -0.25 0.25 0.5]	Center
[0.25 0.5 1 1]	Right

TABLE III. LINGUISTIC TERM OF AREA

Linguistic Term of Area	
Area (Pixel)	Linguistic Term
[600 600 2000 3500]	Far
[2000 3500 5500 7000]	Middle
[5500 7000 9000 9000]	Near

TABLE IV. LINGUISTIC TERM OF MOTOR DC

Linguistic Term of Motor DC		
Motor Speed (PWM)	VLeft	VRight
[0 0 25 50]	Very Slow	Very Slow
[25 50 75 100]	Slow	Slow
[75 100 125 125]	Fast	Fast

Table IV shows the linguistic terms of the left and right DC motors as output. The two DC motors used have the same speed, which is between 0-125 PWM (Pulse Width Modulation). Both motors are in “Very Slow” condition when they have a speed of 0-50 PWM, are in a “Slow” condition at a speed of 25-100 PWM, and have a “Fast” condition with a speed of 75-125 PWM. This speed is set so that the robot can move to follow the object, not too fast or too slow.

The sensor input is divided into two fuzzy members, namely Turn and Area. Turn means position of the object and Area means the distance between the object and the robot. For the membership function of Turn can be seen in Fig. 4 and for the membership function of Area can be seen in Fig. 5.

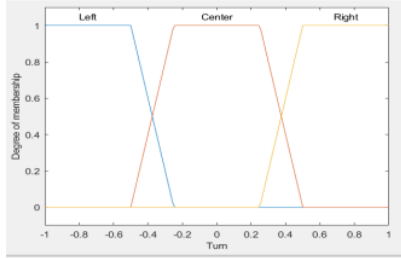

Fig. 4. Membership function of Turn.

$$\mu_{Left} = \begin{cases} 1, & x \leq -0.5 \\ \frac{-0.25-x}{0.25}, & -0.5 \leq x \leq -0.25 \\ 0, & x \geq -0.25 \end{cases} \quad (1)$$

$$\mu_{Center} = \begin{cases} 1, & -0.25 \leq x \leq 0.25 \\ \frac{-0.5-x}{-0.25}, & -0.5 \leq x \leq -0.25 \\ \frac{0.5-x}{0.25}, & 0.25 \leq x \leq 0.5 \\ 0, & \text{other,} \end{cases} \quad (2)$$

$$\mu_{Right} = \begin{cases} \frac{0.5-x}{-0.25}, & 0.25 \leq x \leq 0.5 \\ 1, & 0.5 \leq x \leq 1 \\ 0, & \text{other.} \end{cases} \quad (3)$$

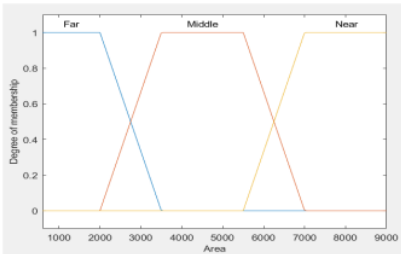

Fig. 5. Membership function of Area.

$$\mu_{Far} = \begin{cases} 1, & x \leq 2000 \\ \frac{3500-x}{1500}, & 2000 \leq x \leq 3500 \\ 0, & x \geq 3500 \end{cases} \quad (4)$$

$$\mu_{Middle} = \begin{cases} 1, & 3500 \leq x \leq 5500 \\ \frac{2000-x}{-1500}, & 2000 \leq x \leq 3500 \\ \frac{7000-x}{1500}, & 5500 \leq x \leq 7000 \\ 0, & \text{other,} \end{cases} \quad (5)$$

$$\mu_{Near} = \begin{cases} \frac{7000-x}{-1500}, & 5500 \leq x \leq 7000 \\ 1, & 7000 \leq x \leq 9000 \\ 0, & \text{other.} \end{cases} \quad (6)$$

then for the right and left DC Motor speed, both have the same speed (0-125 PWM), so they are made into one display in Fig.6.

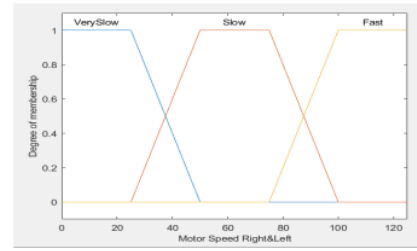

Fig. 6. Membership function of Motor Right and Left.

$$\mu_{VSlow} = \begin{cases} 1, & x \leq 25 \\ \frac{50-x}{25}, & 25 \leq x \leq 50 \\ 0, & x \geq 50 \end{cases} \quad (7)$$

$$\mu_{Slow} = \begin{cases} 1, & 50 \leq x \leq 75 \\ \frac{25-x}{-25}, & 25 \leq x \leq 50 \\ \frac{100-x}{25}, & 75 \leq x \leq 100 \\ 0, & \text{other,} \end{cases} \quad (8)$$

$$\mu_{Fast} = \begin{cases} \frac{100-x}{-25}, & 75 \leq x \leq 100 \\ 1, & 100 \leq x \leq 125 \\ 0, & \text{other.} \end{cases} \quad (9)$$

Table V. shows the rules used in this study using the fuzzy method. In this study, there is nine rules that used for the fuzzy logic rule. Each rule has its own conditions.

TABLE V. FUZZY LOGIC RULE

Rule	Input		Output	
	Turn	Area	VRight	VLeft
R1	Left	Near	Slow	VSlow
R2	Left	Middle	Fast	VSlow
R3	Left	Far	Fast	Slow
R4	Center	Near	VSlow	VSlow
R5	Center	Middle	Slow	Slow

Rule	Input		Output	
	Turn	Area	VRight	VLeft
R6	Center	Far	Fast	Fast
R7	Right	Near	VSlow	Slow
R8	Right	Middle	VSlow	Fast
R9	Right	Far	Slow	Fast

2. Pixy Camera

On the Pixy camera, a software called PixyMon is used. PixyMon itself is used to recognize objects, give signatures to objects, and also set the range of objects that can be seen by the Pixy camera. In Fig.7 and 8, it can be seen that Signature 1 is named "Object" and the range is set to 5.000000. It is because we only use one object and Signature 1 we used in PixyMon, but we can use another "Signature label" if we want. We also used "Min brightness" for 0.012 and the camera brightness is 81, we can control it depends on what we need. It is because the lightning in the room will affect for the test results.

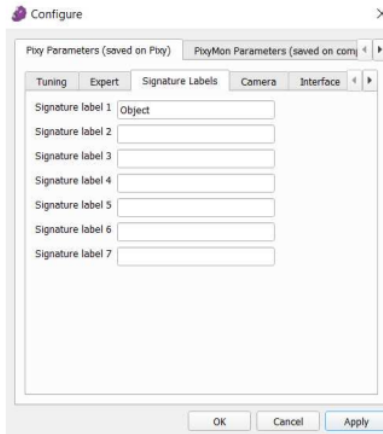

Fig. 7. PixyMon signature labels.

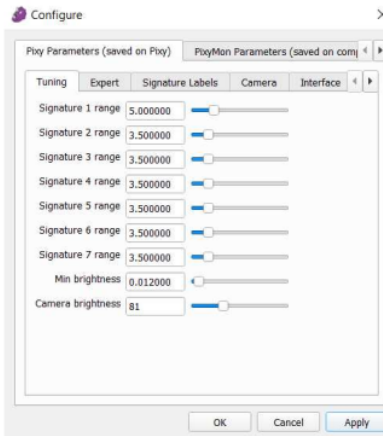

Fig. 8. PixyMon tuning.

III. RESULT AND ANALYSIS

A. Fuzzy Logic

In testing, simulations were carried out with several supporting software (simulation software and Arduino IDE) and comparisons were made with manual calculations were carried out to see the application of the fuzzy control system method used. In this test, inputs are used with a Turn of 0.6, and Area of 6000. The test results can be seen below.

1. Determine the Fuzzy Set

In determining the fuzzy set, it is necessary to find the degree of membership of the membership function used. Input Turn is 0.6 and Area is 6000, these two data are included in Rule [7] Right and Near, and Rule [8] Right and Middle. The equation is obtained from:

Turn:

$$\mu_{Right}[0.6] = 1$$

Area:

$$\mu_{Near}[6000] = \frac{7000-6000}{1500} = 0.67$$

$$\mu_{Middle}[6000] = \frac{5500-6000}{-1500} = 0.33$$

2. The Function Implication

The implication function used in this process is the MIN function, because the fuzzy rule base formed is the AND function. For the MIN function, the minimum membership degree of the input variable is the output. Based on the rule base in Table 1, in this case the conditions that display only two rules that give values, namely R [7] and R [8].

[R7] : IF Turn is Right **And** Area is Near **Then** Right motor is VSlow and left motor is Slow.

$$\begin{aligned} \alpha_{R7} &= \mu_{Right} \cap \mu_{Near} \\ \alpha_{R7} &= \min(\mu_{Right}, \mu_{Near}) \\ \alpha_{R7} &= \min(1, 0.67) = 0.67 \end{aligned}$$

[R8] : IF Turn is Right **And** Area is Middle **Then** Right motor is VSlow and left motor is Fast.

$$\begin{aligned} \alpha_{R8} &= \mu_{Right} \cap \mu_{Middle} \\ \alpha_{R8} &= \min(\mu_{Right}, \mu_{Middle}) \\ \alpha_{R8} &= \min(1, 0.33) = 0.33 \end{aligned}$$

3. Defuzzification

Defuzzification is the process of transforming the degree of membership of the fuzzy set into a definite decision form or with an actual value. The center of gravity technique is a comprehensive and useful defuzzification method in this study. The most common and frequently used method is to stack all the trapezoids on top of each other, thus forming a single geometry. Then do the calculations on the fuzzy centroid or center in this way.

Fig.9 shows the results of the calculations on the software toolbox used, which when Turn is 0.6 and Area is 6000, the resulting value is 20.80 for the right DC Motor and 85.60 for the left DC Motor. In addition, in Fig. 10 the results obtained through the Arduino IDE with the same Turn and Area values. The result is 21.11 for the right DC motor, and 85.20 for the left DC motor.

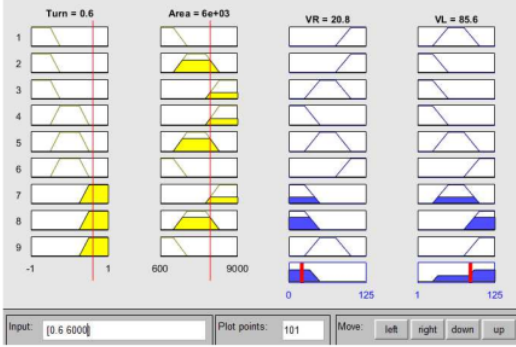

Fig. 9. Software simulation.

```

Entrance:
Result:
          Turn: 0.60, Area: 6000
          Vr: 21.11, and Vl: 85.20
  
```

Fig. 10. Arduino IDE serial monitor.

$$Z^* = \frac{\int_0^{33.25} 0.67z dz + \int_{33.25}^{50} \left(\frac{50-z}{25}\right) z dz}{\left(\frac{16.75 \times 0.67}{2}\right) + (33.25 \times 0.67)}$$

$$Z^* = \frac{588.9035416667}{27.88875} = 21.09 \quad (13)$$

and

$$Z^* = \frac{\int_{75}^{100} \left(\frac{100-z}{25}\right) z dz + \int_{75}^{83.25} 0.33z dz + \int_{83.25}^{125} 0.33z dz}{\left(\frac{16.75 \times 0.67}{2}\right) + (33.25 \times 0.67)}$$

$$Z^* = \frac{2371.825}{27.88875} = 85.04 \quad (14)$$

The results of the test using the software toolbox and Arduino IDE run according to the design. The input given is a Turn worth 0.6 and an area of 6000, then the robot will move to the right. The value obtained by manual calculation is 21.09 for the right DC motor, and 85.04 for the left DC motor. After doing a comparison with the results of the software output with the same amount of input. The results on simulations and calculations prove that the calculations and experiments run well, with results that are not much different.

B. Error Rate

TABLE VI. ERROR RATE

Linguistic Term of Motor DC		
Calculation Type	VRight (PWM)	VLeft (PWM)
Arduino IDE	21.11	85.20
Manual Calculation	21.90	85.04
Simulation Software	20.80	85.60

After calculating and simulating fuzzy logic using software, a comparison is also made to measure the error rate of the system that has been created. From Table VI, it can be

seen that there is a difference in output between PWM right motor with left motor PWM output for each calculation result fuzzy. To find out the difference in error, it can be calculated as follows:

Right Motor

$$\%error = \frac{20.80 - 21.11}{20.80} \times 100\%$$

$$\%error = 1.49\%$$

Left Motor

$$\%error = \frac{85.6 - 85.2}{85.6} \times 100\%$$

$$\%error = 0.47\%$$

C. Pixy Camera

Experiments with the Pixy camera were carried out using the Pixymon software. The experiment was carried out with object recognition on the camera and adjusted to the appearance on Pixymon. It can be seen, the object can be read properly by the sensor with the name "Object" in the Fig.11.



Fig. 11. PixyMon detection.

In Fig. 11 we can see the object used is green, this is because the previous color test resulted in better green color detection with indoor lighting of 94 Lux.

IV. CONCLUSION

In this study, the robot navigation system is carried out by recognizing objects using a vision sensor (Pixy camera). After the object is introduced, the sensor will provide input to the microcontroller (Arduino Mega 2560) which then gives a command to the DC motor to move in the direction the object is going with the set speed. It is known that the Pixy camera can recognize objects that have been marked properly and can be continued with a calculation process to determine their speed. In its manufacture, the fuzzy logic control Mamdani method is used which is intended so that the robot can move well. In this study used closed loop control system, so there is a feedback from the input become input in the block diagram.

Experiments were carried out with the software toolbox as a calculation of the method used. Use a Turn value of 0.6 and an Area of 6000, the result is 20.80 for the right DC Motor output and 85.60 for the left DC Motor. With the results of manual calculations, the speed for the right DC Motor is 21.09 and the left DC Motor is 85.04. In addition,

experiments were also carried out using the Arduino IDE Software, which obtained results of 21.11 for the right DC Motor and 85.20 for the left DC Motor. The error rate obtained is 1.49% for the right motor and 0.47% for the left motor. From the results of experiments and calculations carried out, almost the same results were found. With the results of calculations and experiments carried out, it can be seen that the system can work well. So that the robot can be used in accordance with the directions given.

REFERENCES

- [1] Z. Lubis, "Metode baru robot pengantar menu makanan menggunakan android dengan kendali pid berbasis mikrokontroler," *JET (Journal Electro Technology)*, 2018, vol. 3, p. 105-115.
- [2] A. E. Setiawan, A. Rusdinar, R. Mardiaty, & E. A. Z Hamidi, "ANN Design Model to Recognize The Direction of Multi-Robot AGV," *2021 7th International Conference on Wireless and Telematics (ICWT)*. IEEE, 2021, pp. 1-4.
- [3] Kautsar, S., Widiawan, B., Etikasari, B., Anwar, S., Yunita, R. D., & Syai'in, M, "A simple algorithm for person-following robot control with differential wheeled based on depth camera," *2019 International Conference on Computer Science, Information Technology, and Electrical Engineering (ICOMITEE)*. IEEE, 2019, pp. 114-117.
- [4] C. Zou, "Designing an Electric Car Toy on Our Own: A Human-following Robot Using Pixy Cam Visual Detection," 2019.
- [5] R. Mardiaty, B. R. Trilaksono, Y. S. Gondokaryono, and S. S. Wibowo, "Motorcycle's Trajectory Tracking Model Based on Polynomial Least-Squares Approximation," *Advances Science Letters*, 2017, vol. 23, no. 5, pp. 4537-4541.
- [6] R. Mardiaty, B. R. Trilaksono, Y. S. Gondokaryono, and S. S. Wibowo, "Motorcycle movement model based on Markov chain process in mixed traffic," *Int. J. Electrical and Computer Engineering (IECE)* 8, 2018, no. 5, pp. 3149-3157.
- [7] R. Mardiaty, B. R. Trilaksono, S. S. Wibowo, and D. S. Laila, "Modeling Motorcycle Maneuvering in Urban Scenarios Using Markov Decision Process with a Dynamical-Discretized Reward Field," *International Journal of Automotive Technology*, 2021, no. 22, pp. 967-977.
- [8] Zaki, Alwan Abdul, E. Mulyana, and R. Mardiaty, "Modeling Wall Tracer Robot Motion Based on Fuzzy Logic Control," *2020 6th International Conference on Wireless and Telematics (ICWT)*. IEEE, 2020, pp. 1-6.
- [9] F. Wildani, R. Mardiaty, E. Mulyana, & A. E. Setiawan, "Semi-Autonomous Navigation Robot Using Integrated Remote Control And Fuzzy Logic," *2021 7th International Conference on Wireless and Telematics (ICWT)*. IEEE, 2021, pp. 1-5.
- [10] Antonelli, Gianluca, S. Chiaverini, and G. Fusco, "A fuzzy-logic-based approach for mobile robot path tracking," *IEEE transactions on fuzzy systems*, 2017, vol. 15.2, pp. 211-221.
- [11] Ahmad, M. F., Rong, H. J., Alhady, S. S. N., Rahiman, W., & Othman, W. A. F. W, "Colour tracking technique by using pixy CMUcam5 for wheelchair luggage follower," *2017 7th IEEE International Conference on Control System, Computing and Engineering (ICCSCCE)*. IEEE, 2017, pp. 186-191.
- [12] Anindyaguna, Khalid, N. C. Basjaruddin, and D. Saefudin, "Overtaking assistant system (OAS) with fuzzy logic method using camera sensor," *2016 2nd International Conference of Industrial, Mechanical, Electrical, and Chemical Engineering (ICIMECE)*. IEEE, 2016.
- [13] Perkasa, S. Dani, P. Megantoro, and H. A. Winarno, "Implementation of a camera sensor pixy 2 CMUcam5 to a two wheeled robot to follow colored object," *Journal of Robotics and Control (JRC)*, 2021, vol. 2.6, pp. 469-501.
- [14] Ng, Y. L., Lim, C. S., Danapalasingam, K. A., Tan, M. L. P., & Tan, C. W, "Automatic human guided shopping trolley with smart shopping system," *Jurnal teknologi*, 2015, vol. 73(3).
- [15] M. D. Fadillah, N. Ismail, R. Mardiaty, & A. Kusdiana, "Fuzzy Logic-Based Control System to Maintain pH in Aquaponic," *2021 7th International Conference on Wireless and Telematics (ICWT)*. IEEE, 2021, pp. 1-4.

ORIGINALITY REPORT

25%

SIMILARITY INDEX

15%

INTERNET SOURCES

22%

PUBLICATIONS

6%STUDENT PAPERS

MATCH ALL SOURCES (ONLY SELECTED SOURCE PRINTED)

6%

★ Fikri Ahmad Fauzi, Edi Mulyana, Rina Mardiaty, Aan Eko Setiawan. "Fuzzy Logic Control for Avoiding Static Obstacle in Autonomous Vehicle Robot", 2021 7th International Conference on Wireless and Telematics (ICWT), 2021

Publication

Exclude quotes Off

Exclude matches Off

Exclude bibliography Off