

# Prototype of Mobile Robot Tracking Object Using Sensor Vision

Tiara Syantika Dewi

*Department of Electrical Engineering  
UIN Sunan Gunung Djati Bandung  
Bandung, Indonesia  
tiaraasyantika@gmail.com*

Aan Eko Setiawan

*Department of Electrical Engineering  
Telkom University  
Bandung, Indonesia  
aaneko37@gmail.com*

Rina Mardiaty

*Department of Electrical Engineering  
UIN Sunan Gunung Djati Bandung  
Bandung, Indonesia  
r\_mardiaty@uinsgd.ac.id*

Yumna

*Ushuludin Faculty  
UIN Sunan Gunung Djati Bandung  
Bandung, Indonesia  
yumnayumna@uinsgd.ac.id*

Lia Kamelia

*Department of Electrical Engineering  
UIN Sunan Gunung Djati Bandung  
Bandung, Indonesia  
lia.kamelia@uinsgd.ac.id*

Ridwan Rustandi

*Da'wah and Communication Faculty  
UIN Sunan Gunung Djati Bandung  
Bandung, Indonesia  
ridwanrustandi@uinsgd.ac.id*

**Abstract**— Science and technology at this time are developing so rapidly. Accuracy, effectiveness, and efficiency are the main things offered with the development of technology. One form of this aspect is the creation of an automatic randomization system of an object with a mobile robot system. This study aims to produce a mobile robot prototype for object tracking that utilizes sensor vision as the main component in tracking an object, where the system built can distinguish an object based on color and can approach the object automatically because in this robot an autonomous mobile robot system is applied. In this research, it combines two main components, namely hard components and soft components. The hard components are composed of the Pixy CMU Cam5 as a sensor vision to recognize objects that have been targeted, the DC motor is used as a robotic locomotor to approach the intended object, the L298N Driver Shield Motor as the DC motor processing of the microcontroller, and Arduino UNO as the main microcontroller in the mobile robot tracking object prototype. The soft components consist of the PixyMon application which is used for the process of configuring digital images of color-based objects and the Arduino IDE which is used to write robotic movement system programs when they have recognized objects which are then uploaded into the microcontroller. As a result of the tests that have been carried out, the DC motor can move according to the specifications that have been made and the pixy sensor vision can capture pixels of well-configured colors.

**Keywords**— tracking object, Pixy CMU Cam5, mobile robot, PixyMon.

## I. INTRODUCTION

Object tracking is a tracking process that can be used to search for an object based on color, shape, line, or other things that have been predetermined [1][2]. The application of object tracking can be used as a system for finding goods in the industrial field, where the application of this system can minimize errors in the element of accuracy that exist in the use of human worker services [3]. This object tracking system is implemented in mobile robots. Thus, robots with this system not only recognize objects, but when the goods are tracked, the robot will move towards the direction of the item [4]. One of the important elements in object tracking is object recognition. Because in its implementation, in tracking and detection there will be a wide variety of object colors [5]. The recognition of the object uses a vision sensor in the form of a Pixy CMU Cam5.

The vision sensor in object tracking functions as the 'eye' in the robot just as does the eye on the human body, using the Pixy CMU Cam5. Pixy CMU Cam5 can process images viewed using the PixyMon application so that the data sent is already the required information [6][7]. Then this camera does not need any additional software and other methods to configure the predetermined digital image. Pixy CMU Cam5 can recognize up to 7 different color signatures. The way pixy cam works is by calculating the color and saturation of each color pixel from the image sensor and using it as a color filtering parameter [8], so that the digital image captured will be more accurate and can minimize color-based object recognition errors. In addition, the pixy cam can be adjusted the distance between the camera and the object [9], to minimize the occurrence of collisions between the object and the robot body.

Several studies have been carried out on mobile robots with object recognition for tracking, detecting, or sorting objects, either using camera, sensors, or other similar methods. In the research conducted by M. Rizky Vira Aditya, et al. made a mobile garbage collection robot using a Webcam camera, with the captured digital imagery will be processed using the HVS method and the radius method to determine the minimum distance between the signs contained in each room and the robot [10]. Furthermore, the research conducted by Abd. Rahman Patta and Irmawati Iskandar conducted an experimental method in garbage collection where the object was detected using ultrasonic sensors [11]. Research on object trackers using fuzzy logic methods on robotic movements and tracking 2D digital images using visual studio software was carried out by M. Khairudin, et al [12]. Research conducted by M. Jain, et al. was conducted in 2019, regarding mobile robot pick and place, where the detection of objects using ultrasonic sensors [13]. Research on object detection using a coordinate methods and RP LIDAR concept on robot movements was carried out by Satria Fakhri, et al [14].

This mobile robot tracking object works automatically, where the programmed system is embedded in the Arduino UNO microcontroller so that there is no need for commands from the user manually in its application. After running, several problems arise, one of which is that the robot will continue to approach the target as long as the object it recognizes is detected by the camera even though the distance

between the object and the robot's body is very close, so that the robot can hit the tracked object. The distance between the robot and the object is set in the "range" of "configure" section at the PixyMon software, to minimize collisions.

The implementation of sensor vision using Pixy CMU Cam5 in this study is useful for streamlining digital image processing, and also the system of this camera is pixel-based digital image tracking to minimize errors in object tracking.

## II. DESIGN OF THE ROBOT

### A. System Design

Designing is carried out as a process of describing system flows implemented on tools that have been designed. At the system design stage, software and hardware design are carried out, where hardware design discusses the design scheme of robotic electronic components and configurations on Arduino UNO devices. While the software design discusses the design of system programs on the Arduino IDE and the object recognition process on the Pixy CMU Cam5 in the PixyMon application.

There are three stages of the system in this robot's design: input, process, and output. The Pixy CMU Cam5 is used as a robot vision sensor for recognizing objects and as a distance measure between the object and the robot body. It is positioned on the front of the robot. The results of the recognition of objects captured by the camera and distance measurements will be processed by Arduino UNO. It will later affect the output in the form of the movement of two DC motors installed on the right and left of the robot body. The block diagram of hardware is shown in Fig. 1.

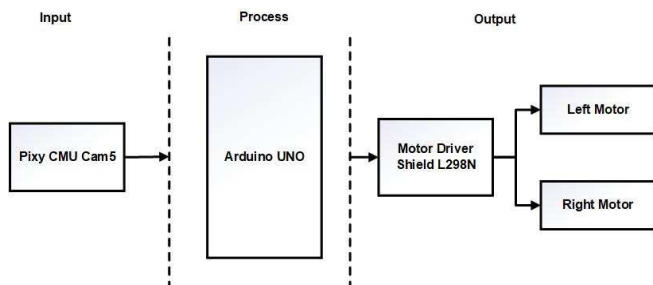

Fig. 1. Diagram of the robot control system.

The three stages of the system that have been designed are connected or related to each other, to produce robotic work that can track objects. The electronic component that acts as an input is the Pixy CMU Cam5. The pixy camera will recognize and capture the target object's colour pixels and position, which will provide input to the DC motor to move forward to approach the object.

The process stage is the main stage of the system. The results of the recognition / capturing of colour pixels from the object will be processed in the Arduino UNO microcontroller by adjusting the colour and position of the object with the program. It can set the movement of the DC motor to the right and left so that the robot can approach the intended object.

The program at the process stage controls the movement of DC motors towards the object. The result is taken from the data processing on Arduino UNO after receiving input from the Pixy camera.

### B. Hardware Design

A mobile object tracking robot is a mobile robot that can track an object, so a DC motor and sensor vision are needed for the tool to run according to what is desired. A microcontroller is needed as a processor for the data obtained, and then the results of processing the data are processed again by the motor driver to drive the DC motor. In this research, several components were connected, so that a schematic of the robotic circuit was obtained as shown in Fig. 2. The components consist of an Arduino UNO microcontroller, an L298N shield driver motor, a Pixy CMU Cam5, a DC motor, and an 11V Lipo battery.

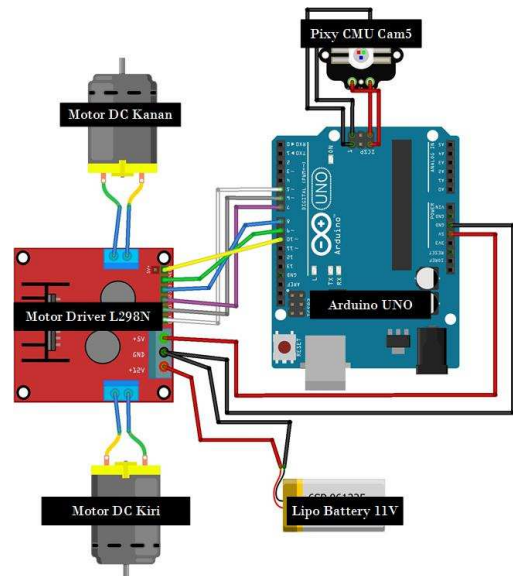

Fig. 2. The scheme of the robotic circuit.

### C. Software Design

After the hardware design is done, then the software design is carried out. The software used is the Arduino IDE to write a program which then sends the compilation results to Arduino UNO. The PixyMon application to configure Pixy and manage the marking, distance and color detection of objects, and Fritzing software to design the scheme of the robot created. Fig. 3 is an algorithm or flowchart of system tracking object using a mobile robot.

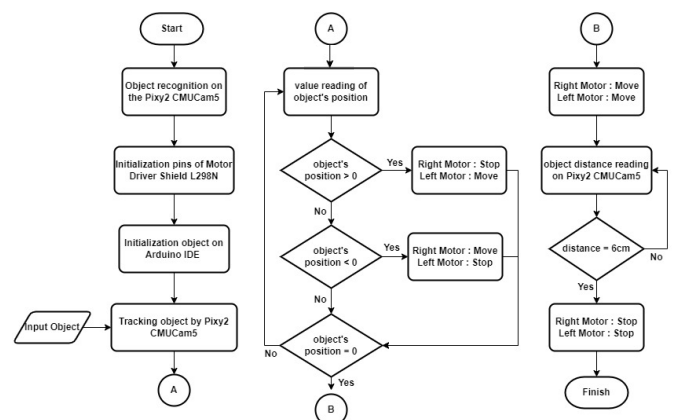

Fig.3. Mobile robot system tracking object flowchart.

### III. SYSTEM IMPLEMENTATION

Mobile Robot Prototype for Object Tracking Using Vision Sensors has been successfully created. The robot uses the Pixy CMU Cam5 as a vision sensor and a motor for its movement. Fig. 4 shows the prototype of the robot.

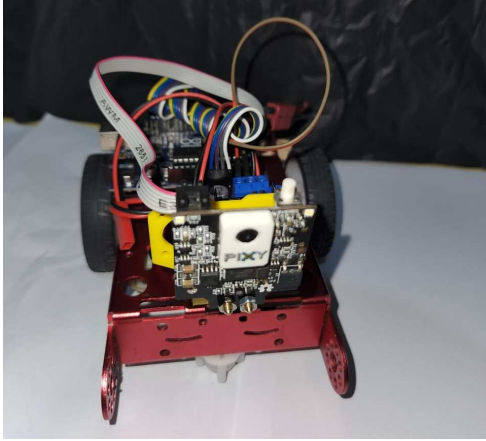

Fig. 4. The prototype of the robot

### IV. SOFTWARE TESTING AND ANALYSIS

After designing the tools made, proceed to the testing stage. At this testing stage, an object with a dark green colour is used as a target. On the pixy camera, the image capture distance is set at 10-70cm from the camera to the object. In its condition, this test is carried out in a half-open room with a yellow background (wall) so that there is additional light from the sun in a bright room. Several tests were carried out regarding object tracking data obtained from pixy cameras.

#### A. Object Color Testing

The Pixy as sensor vision can remember or mark objects with as many as seven color signatures, without any color provisions that the pixy sensor vision can remember. In this test, seven colors with almost similar colors were used. The results of the tests can be seen in TABLE I.

TABLE I. OBJECT COLOR TESTING

| Colour      | Detection Results |
|-------------|-------------------|
| Dark Blue   | Detected          |
| Light Blue  | Detected          |
| Dark Green  | Detected          |
| Light Green | Detected          |
| Dark Red    | Detected          |
| Pink        | Detected          |
| Yellow      | Detected          |

From the test results, it is stated that dense and soft color types can be detected by pixy sensor vision, although there are almost similar colors when viewed with the human eye. However, there are some notes on each test.

In dark blue testing, the pixy sensor vision can only recognize the color at the distance where the color is configured, and at other distances, the camera cannot

recognize objects with that color. In light blue color testing, the pixy sensor vision can only capture or recognize the color of the object at a distance when the object color is configured, because when the object is stored at a long-distance or closer to the camera, the pixy sensor vision will look like white.

In dark green testing, the pixy sensor vision can recognize the color of objects at close or far distances, but cannot be recognized when the object is very close to the pixy sensor vision. In light green color testing, pixel capture on the pixy sensor vision frame produced the same results as light blue color testing.

In dark red testing, the pixy sensor vision can recognize the color of objects at close or far distances, but cannot be recognized when the object is very close to the pixy sensor vision. In the pink color test, the pixel capture on the pixy sensor vision frame produced the same results as the light blue and light green color test.

In yellow color testing, the pixy sensor vision can only capture or recognize the color of the object at a distance when the object color is configured, when the object is kept away or approached by the camera, then the object cannot be recognized by the pixy sensor vision. Fig. 5 display the process of object spacing testing

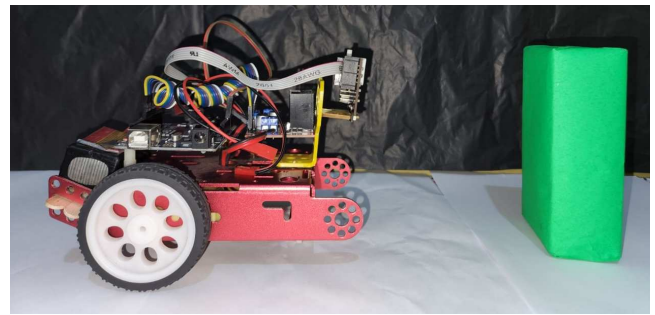

Fig. 5. The testing process

#### B. Object Spacing Testing

In this test, four variations were carried out where the object was green with a background using a black cloth, and the background followed the existing conditions or without using an additional background. The test is against the capture of digital imagery of objects when the light feature on the pixy camera is used and not used. The results of the tests can be seen in TABLE II.

TABLE II. FIRST DISTANCE TESTING (ADDITIONAL BACKGROUND USING BLACK CLOTH AND WITHOUT USING THE LIGHT FEATURE ON THE SENSOR VISION)

| Distance of Object to Camera (cm) | Detection Results |
|-----------------------------------|-------------------|
| 10                                | Detected          |
| 20                                | Detected          |
| 30                                | Detected          |
| 40                                | Detected          |
| 50                                | Detected          |
| 60                                | Detected          |
| 70                                | Detected          |

Additional background using black cloth and without the light feature on the sensor vision. The results of this test can be seen in TABLE II. The additional black background can absorb light well, so the object's colour is difficult to reflect light which can make the object's colour brighter or darker. The test shows that the system can detect the object for a distance of 10 cm – 70 cm.

The test results with the additional background using a black cloth and the light feature on the sensor vision can be seen in TABLE III.

TABLE III. TESTING FROM THE CLOSEST DISTANCE (WITH THE ADDITIONAL BACKGROUND, USED A BLACK CLOTH AND USED THE LIGHT FEATURE ON THE SENSOR VISION )

| Distance of Object to Camera (cm) | Detection Results |
|-----------------------------------|-------------------|
| 10                                | Detected          |
| 20                                | Not Detected      |
| 30                                | Not Detected      |
| 40                                | Not Detected      |
| 50                                | Not Detected      |
| 60                                | Not Detected      |
| 70                                | Not Detected      |

Using the light feature on the Pixy vision sensor in the presence of natural light and configuring the object's colour nearby can set the colours on the objects captured by the Pixy camera to very bright and the background dark. This condition creates that the colour recognition of objects on Pixy cameras may change when objects are kept away from the camera. The results of this test can be seen in TABLE IV at the condition when an object is configured from the farthest distance of 70 cm to 10 cm using the PixyMon application.

TABLE IV. TESTING FROM THE FARTHEST DISTANCE

| Distance of Object to Camera (cm) | Detection Results |
|-----------------------------------|-------------------|
| 70                                | Detected          |
| 60                                | Detected          |
| 50                                | Detected          |
| 40                                | Detected          |
| 30                                | Detected          |
| 20                                | Detected          |
| 10                                | Not Detected      |

When the object's colour is configured from the farthest distance, the light feature on the pixy camera reflects more light on a black background. The light can absorb the object's colour when the distance is changed, so it does not have much effect on the detection process.

The following testing process has done without using additional backgrounds and without using the light feature on the Pixy sensor vision. The results of this test can be seen in TABLE V.

At a distance of 40 cm, the object is no longer detected by the pixy camera. It is because when the object is close to the camera, the colour will be more intense compared to a long distance, and the object's colour will be reflected with the existing light so that it looks like a light green.

TABLE V. THIRD DISTANCE TESTING (WITHOUT USING ADDITIONAL BACKGROUNDS AND WITHOUT USING THE LIGHT FEATURE)

| Distance of Object to Camera (cm) | Detection Results |
|-----------------------------------|-------------------|
| 10                                | Detected          |
| 20                                | Detected          |
| 30                                | Detected          |
| 40                                | Not Detected      |
| 50                                | Not Detected      |
| 60                                | Not Detected      |
| 70                                | Not Detected      |

The following testing condition is the testing without using additional backgrounds and using the light feature on the pixy sensor vision. The results of this test can be seen in TABLE VI.

TABLE VI. DISTANCE TESTING (WITHOUT USING ADDITIONAL BACKGROUNDS AND USING THE LIGHT FEATURE)

| Distance of Object to Camera (cm) | Detection Results |
|-----------------------------------|-------------------|
| 10                                | Detected          |
| 20                                | Not Detected      |
| 30                                | Not Detected      |
| 40                                | Not Detected      |
| 50                                | Not Detected      |
| 60                                | Not Detected      |
| 70                                | Not Detected      |

Using the light feature on the pixy vision sensor when there is natural light and configuring the object's colour nearby can make the colours on the objects captured by the pixy camera very bright and the background dark. So that if the distance is far enough from the camera, the colour will change because the colour of the existing background reflects the light.

From the analysis, it can be concluded that the additional black background can absorb the existing light so that the capture of colour pixels on the camera becomes more stable than without using an additional background. Besides, the colour configuration of objects at too close a distance makes the camera only able to recognize these colours at a very close distance.

### C. Position Test (turn)

In the system program created, there are inputs from pixy sensor visions, one of which is the position data of the captured object. Therefore, a position test is carried out, and

the results can be seen in TABLE VII. The following condition is: the object is on the leftmost frame of the pixy sensor vision. The results of this test can be seen in TABLE VIII.

The overall test results prove that the tracking robot can trace objects based on predetermined scenarios. When the object is on the left, the robot will rotate to the right and vice versa.

TABLE VII. TEST THE TURN OBJECT ON THE RIGHT

| Distance of Object to Camera (cm) | Detection Results |
|-----------------------------------|-------------------|
| 10                                | 0,98              |
| 20                                | 0,98              |
| 30                                | 0,98              |
| 40                                | 0,98              |
| 50                                | 0,98              |
| 60                                | 0,98              |
| 70                                | 0,96              |

TABLE VIII. TEST THE TURN OBJECT ON THE LEFT

| Distance of Object to Camera (cm) | Detection Results |
|-----------------------------------|-------------------|
| 10                                | -0,31             |
| 20                                | -0,34             |
| 30                                | -0,57             |
| 40                                | -0,65             |
| 50                                | -0,71             |
| 60                                | -0,74             |
| 70                                | -0,80             |

## V. CONCLUSION

The research results show that mobile robot tracking objects can be designed using pixy sensor visions with a more accessible and efficient digital image configuration. The slight difference in colour remains undetectable by the pixy sensor vision. Pixel calculation as the way this pixy sensor vision works can maximize colour-based object recognition. The movement of the DC motor to approach the object when it is tracked has been following the desired specifications. When the turned object is at a value of less than -1, the suitable DC motor will rotate. When the turned object is at a value of  $< 1$ ,

the left DC motor will rotate, and when the turned object is at a predetermined value between dead zones, the right and left DC motors will rotate with the same PWM to produce a straight forward robot movement.

## REFERENCES

- [1] Ojha, Shipra, and Sachin Sakhare. "Image processing techniques for object tracking in video surveillance-A survey." 2015 International Conference on Pervasive Computing (ICPC). IEEE, 2015.
- [2] Collins, Robert T., Yanxi Liu, and Marius Leordeanu. "Online selection of discriminative tracking features." IEEE transactions on pattern analysis and machine intelligence 27.10 (2005): 1631-1643.
- [3] Frankó, Attila, Gergely Vida, and Pal Varga. "Reliable identification schemes for asset and production tracking in industry 4.0." Sensors 20.13 (2020): 3709.
- [4] Rubio, Francisco, Francisco Valero, and Carlos Llopis-Albert. "A review of mobile robots: Concepts, methods, theoretical framework, and applications." International Journal of Advanced Robotic Systems 16.2 (2019): 1729881419839596.
- [5] Yilmaz, Alper, Omar Javed, and Mubarak Shah. "Object tracking: A survey." Acm computing surveys (CSUR) 38.4 (2006): 13-es.
- [6] Hamidi, Eki Ahmad Zaki, Mufid Ridlo Effendi, and Firman Febrianto Asmoro. "Design and Implementation of Model Autonomous Sentry Gun Using Image Processing and Motion Tracking." 2019 IEEE 5th International Conference on Wireless and Telematics (ICWT). IEEE, 2019.
- [7] Ruelas, A., Velázquez, N., Villa-Angulo, C., Acuña, A., Rosales, P., & Suastegui, J. (2017). A solar position sensor based on image vision. Sensors, 17(8), 1742. [8] Sendari, S., Lestari, D., Kusumohadi, C. U., Wibowo, F. S., & Anam, K. (2017, May). Integrating embedded color vision to bioloid robot for playing soccer. In 2017 International Conference on Signals and Systems (ICSigSys) (pp. 297-302). IEEE.
- [9] Ahmad, M. F., Rong, H. J., Alhady, S. S. N., Rahiman, W., & Othman, W. A. F. W. (2017, November). Colour tracking technique by using pixy CMUcam5 for wheelchair luggage follower. In 2017 7th IEEE International Conference on Control System, Computing and Engineering (ICCSCE) (pp. 186-191). IEEE.
- [10] Aditya, M. R. V., Husni, N. L., Pratama, D. A., & Handayani, A. S. (2020). Penerapan Sistem Pengolahan Citra Digital Pendeteksi Warna pada Starbot. Teknika, 14(2), 185-191.
- [11] Patta, Abd Rahman, and Irmawati Iskandar. "Prototype Robot Pemungut Sampah Berbasis Arduino Mega." Jurnal Rekayasa Teknologi Informasi (JURTI) 3.2 (2019): 155-164.
- [12] Khairudin, M., Yatmono, S., Nugraha, A. C., Ikhsani, M., Shah, A., & Hakim, M. L. (2021). Object Detection Robot Using Fuzzy Logic Controller Through Image Processing. In Journal of Physics: Conference Series (Vol. 1737, No. 1, p. 012045). IOP Publishing.
- [13] Jain, M., Sehgal, M., Kalra, Y., Jain, P., Aggarwal, N., Singh, R., ... & Singh, R. (2019, July). Object detection and gesture control of four-wheel mobile robot. In 2019 International Conference on Communication and Electronics Systems (ICES) (pp. 303-308). IEEE.
- [14] Fakhri, S., Mardiaty, R., Mulyana, E., & Priatna, T. (2020, September). Prototype Design for Object Coordinate Detection using RP LIDAR Concept. In 2020 6th International Conference on Wireless and Telematics (ICWT) (pp. 1-6). IEEE.