

rr4

by Rina Mardiati

Submission date: 03-May-2023 07:41AM (UTC+0700)

Submission ID: 2082557967

File name: 2022_ICWT_BLDC.pdf (1.06M)

Word count: 4637

Character count: 23348

Advance BLDC Motor Drive Control for Electric Vehicles

Rina Ristiana
Research Center of Transportation
Technology, National Research and
Innovation agency, Bandung, Indonesia
rina008@brin.go.id
0000-0002-7842-1126

Aam Muharam
Research Center of Transportation
Technology, National Research and
Innovation agency, West Java, Indonesia
aam.muhamam@brin.go.id
0000-0001-8803-7999

Sudirja
Research Center of Transportation
Technology, National Research and
Innovation agency, West Java, Indonesia
sudi016@brin.go.id
0000-0003-2868-9930

Sunarto Kaleg
Research Center of Transportation
Technology, National Research and
Innovation agency, West Java, Indonesia
suna024@brin.go.id
0000-0002-5800-8713

Abdul Hapid
Research Center of Transportation
Technology, National Research and
Innovation agency, West Java, Indonesia
abdu019@brin.go.id
0000-0002-0599-4206

Rina Mardiaty
Department of Electrical Engineering,
UIN Sunan Gunung Djati Bandung, West
Java, Indonesia
r_mardiaty@uinsgd.ac.id
0000-0002-3949-7830

Alexander Christantho Budiman
Research Center of Transportation
Technology, National Research and
Innovation agency, West Java, Indonesia
alex003@brin.go.id
0000-0002-3034-4352

Amin
Research Center of Transportation
Technology, National Research and
Innovation agency, West Java, Indonesia
amin007@brin.go.id
0000-0001-8600-9054

Abstract—Various electric motors have been used as the propulsion system of electric vehicles. This paper proposed advanced BLDC motor drive control with the principle of digital PWM which treats the motor like a digital system. The digital PWM control sets six gate switches on the inverter and selects variations of high duty, low duty, or skip state based on the speed error and the actual motor current. In addition, a proportional control provides a reference current limit. All processes of commutating and generating digital PWM are integrated into the driver. The digital PWM with proportional control can eliminate the process disturbance signal, give a good response, and has a good settling time, it has the potential to be integrated into a motor driver. The BLDC motor drive control with the principle of digital PWM implemented for electric vehicles.

Keywords— *Electric Vehicles, BLDC Motor Driver, Advanced Control, Digital PWM.*

I. INTRODUCTION

Brushless DC motor (BLDC) is an electric motor as a generated system that is applied to electric vehicles as well as industries such as equipment, aerospace, medical, automation. The advantage of BLDC is reliability, high efficiency, high power density, easy maintenance, lighter weight, and low cost. In its implementation, the BLDC motor requires a driver to adjust the change of the stator winding based on the rotor position to the stator winding. Advances in permanent magnet materials, solid state devices, and microelectronics have resulted in drivers as motor drive control. The challenge in the design of the BLDC motor driver is the application of the motor control function (speed/torque) to make it more practical in its implementation [1], [2], and [3].

Generally BLDC motors are automatically relate to the commutator. The essence of the commutator is knowing the rotor position and giving a command to the gate switch to select the phase by giving consecutively voltages so as to generate torque as a motor drive. The voltage supply occurs

when the stator winding is parallel to the rotor poles. It is done alternately. The rotation of the rotor position is to produce the speed motor control that is suitable and given the maximum torque motor.

To determine the commutation timing, a position sensor is needed. One of the mechanical position sensors popularly used is the Hall effect sensor. Generally, three hall sensors are mounted on the stator part, it is done to get six different timing combinations. Each phase winding uses one hall sensor which provides phase voltage signal information with a wide position range of 60° . While the magnet on the rotor passes through the hall sensor, then the sensor gives a signal in a logic value "high" or "low" according to the displacement of the rotor poles (north or south). The hall signal is also used to generate the feedback signal that needed to control the gate switch which is generally a semiconductor device (solid state). The correct gate switch selection command produces accurate rotor position information. It ensures the built drive has stability and a fast dynamic response. By knowing these three combinations of hall sensors, the correct commutation sequence can be determined. Basically, the design of the BLDC motor driver in [4] describes motor speed control in a closed loop by measuring the actual motor speed and comparing it with the measured motor speed so that the gap or speed error is obtained. To eliminate the speed error, the use of proportional plus integral (PI) control can be applied.

Generally, some adjustable control systems for BLDC motors are based on the principle of pulse width modulation (PWM). Conventional PWM schematics (sinusoidal PWM) or digital PWM generators in embedded systems. The principle of PWM works to set the six switches on the inverter (three-phase bridge) which produce duty cycle variations in the PWM signal. The variation of the PWM signal provides the variations for motor input voltage and motor speed and obtain high torque at high loads and high

efficiency at low loads [5]. Several studies have been carried out in the PWM technique, including in [6] presents an FPGA-based PWM technique for speed control of the BLDC motor with three commutation methods, there are trapezoid, sinusoidal, and field oriented control commutation. PWM technique using FPGA is more efficient and gives more smooth speedresponse.

In [7] proposed PWM control method with the firing signals duty cycle length for speed control. The torque output is fed to the PWM for compare it with the triangular waveform which the comparator output is a low or high signal where that signal is change as a chopping signal of the inverter. In [8], methodology generating PWM signal with counter and decoder obtained accurate timing of pulse and pause with SPWM technique. Accuracy of the output signal based on compared a function and carrier signals which allows different phase. PWM digital generator produced signals allows avoiding of any outside disturbances accompanying analog signal methods and usage of additional generators.

This paper proposed advanced BLDC motor drive control with the principle digital PWM which treats the motor like a digital system. The PWM control sets the six gate-switches on the inverter and selects variations a high duty, low duty or a skip state based on the speed error and the actual motor current. In addition, a proportional control provides a reference current limit. All processes of commuting and generating digital PWM is integrated in the driver. The PWM control has potential to be implemented in an Arduino Nano which is used to generate the control signals and gives a good speed response.

The rest of this paper is organized as follows; Section II describes the BLDC motor drive. It is followed by the technique of digital PWM in Section III. Simulation, validation, and discussion are then presented in Section IV. Section V finalizes the paper with the main conclusion.

II. BLDC MOTOR DRIVE

Each BLDC motor has two main parts, namely a rotor in Fig. 1. and a stator in Fig. 1b. The rotor is the part of the motor that rotates due to the electromagnetic force generated by the stator. The rotor is composed of 2 to 8 pairs of rectangular permanent magnet poles which are mounted together with epoxy. The number of magnetic poles is directlyproportional to the motor torque, but opposite to the rpm. If the number of the rotor pole magnets is large then the torquegenerated is getting bigger, but consequently the motor rpm decreased. Torque is also affected by the magnetic flux density. The greater the magnetic flux density, the greater thetorque. The stator is a stationary part of the motor, which functions as a rotating motor field to provide electromagnetic force to the rotor. The stator is made of laminated steel piles and a place for the wire windings. The stator consists of 12 windings and connected by three wires, each of which represents a phase to be plugged in the motor driver circuit. The magnetic field generated by the stator and the rotor rotate at the same frequency.

BLDC motors use a commutation system and controller sothat the on-off selection of the supply voltage to the stator winding must be arranged sequentially and regularly. The commutation change is based on signal information from the hall sensor. The BLDC motor uses three hall sensors as shown in Fig. 2, it mounted on the stator body at a distance of 120° to detect therotor part that is affected by the magnetic

flux. The hall sensoris a transducer that produces a variable voltage and detects therotor phase in the form of magnetic flux also provides the information of the commutation transfer to the controller so that the current flowing remains constant in each phase. Therefore, the commutation process can run simultaneously and continuously [3].

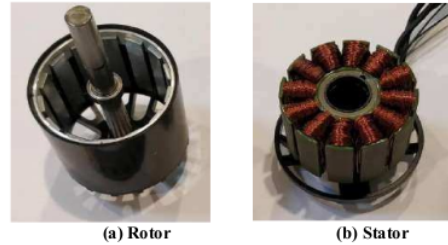

Fig. 1. Motor main part.

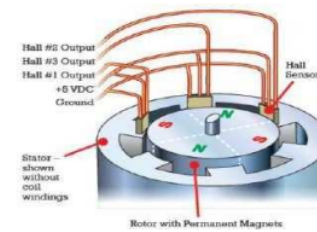

Fig. 2. Sensor hall and its position.

BLDC motor is a type of permanent magnet synchronous motor that is supplied by a DC power source and requires a three-phase AC power source to drive the motor rotor. The fedvoltage generated between the coil and the stator winding willmove the rotor or is called the back electromotive force (EMF). The rotor movement shifts because only two phases are supplied with voltage while one phase is not supplied withvoltage. The phenomenon causes a BLDC motor as well as aDC motor, because the current flowing in the stator coil is similar to a DC motor even though it is actually powered by athree-phase current.

The following shows how a three-phase BLDC motor rotates clockwise and the hall sensor is assigned a north pole by default, as shown in Fig. 3. The three hall sensors are defined as H1, H2 and H3, while the magnetic flux source in the stator winding is defined as A, B and C. The commutation process consists of six steps that are repeated and shaped a cycle which caused the motor to rotate continuously as long as the DC current source is still present. The following describes the steps [9].

In the first step on Fig. 3a, the hall sensors H1 and H3 have high values ("1") as a result of the changing magnetic field so that the controller will flow current in windings B and C. Winding B becomes the north pole and winding C becomes the south pole. The north pole of winding B exerts

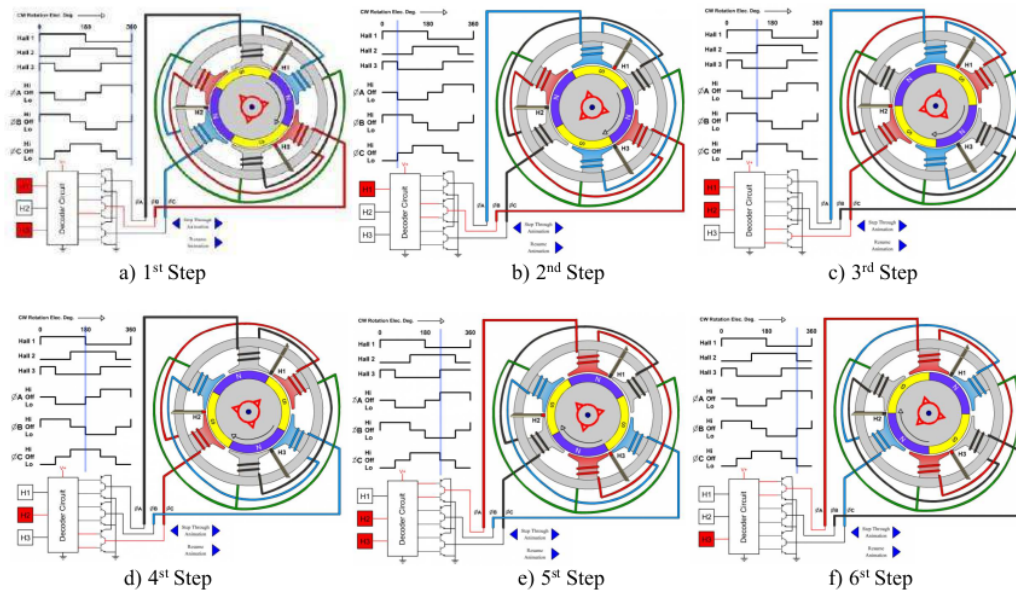

Fig. 3. Procedure BLDC motor [9].

repulsion on the north pole of the rotor magnet, while the south pole of winding C attracts the north pole of the rotor magnet. In the second step on Fig. 3b, only the H1 sensor has a high value, so the controller will instruct that windings A and B must be energized. Winding A becomes the south pole and winding B becomes the north pole. The south pole of winding A will repel the south pole of the rotor magnet, while the north pole of winding B will repel the north pole of the rotor magnet.

In the third step on Fig. 3c, the sensors H1 and H2 will be high, so the controller will instruct the windings A and C to be energized. Winding A remains at the south pole and winding C becomes the north pole. The south pole of winding A will repel the south pole and attract the north pole of the rotor magnet, while the north pole of winding C will attract the south pole of the rotor magnet. In the fourth step on Fig. 3d, only the H2 sensor is "high", so the controller will instruct the B and C windings to be energized. Winding B becomes the south pole and winding C remains the north pole. The south pole of winding B will repel the south pole of the rotor magnet, while the north pole of winding C will repel the north pole of the rotor magnet.

In the fifth step on Fig. 3e, the sensors H2 and H3 will be high, so the controller will instruct the windings A and B to be energized. Winding A remains at the north pole and winding B becomes the south pole. The north pole of winding A will repel the north pole and attract the south pole of the rotor magnet, while the south pole of winding B will attract the north pole of the rotor magnet. In the sixth step on Fig. 3f, only the H3 sensor is "high", so the controller will instruct windings A and C to be energized. Winding A becomes the north pole and coil C remains the south pole. The north pole of winding A will attract the south pole and repel the north pole of the rotor magnet, while the south pole of winding C will attract the north pole of the rotor magnet.

Based on how the BLDC motor works, in the design of the BLDC motor driver, the following points must be considered, which stator winding should be electrified, and setting the angular motor speed. Therefore, the design of the BLDC motor driver as shown in Fig. 4, which consists of a commutation module, a driving switch module, a three phase inverter module, and a generate PWM (pulse width modulation) module.

The inverter module in Fig. 4 (red box) is an electric circuit that functions to drive the motor. The main components are solid state (MOSFET or IGBT) as many as six gate switch that function as switching. The performance regulates and provide electricity to the switch in turns according to the switching time on the command of the driving switch module in Fig. 4 (blue box). The commutation module serves to provide information on signal changes to the driving switch based on the value of the hall sensor signal. Generally, the commutation uses the six-step method as shown in Fig. 3. Therefore, regulating the commutation process, setting the switch and determining the phase voltage sequentially are carried out on these modules.

For setting the angular speed motor is done in the generated PWM module in Fig. 4 (green box). In general, PWM is the manipulation of signal width expressed by pulses in one period to obtain different average voltages. PWM performance is to create a square wave that has a ratio of high pulses to certain low pulses, usually on a 0-100% scale. The square wave has a fixed frequency but the high and low pulse widths are set in one period. The ratio of the high to low pulses will determine the amount of power supplied to the motor. The motor speed control by the PWM technique is set the duty cycle as desirable. The larger the duty cycle, the faster the motor speed, and conversely the smaller the duty cycle, the slower the motor speed. A duty cycle is a pulse condition at the peak of the wave or the high value in one period. An example can be seen in Fig. 4 (yellow box), square pulses

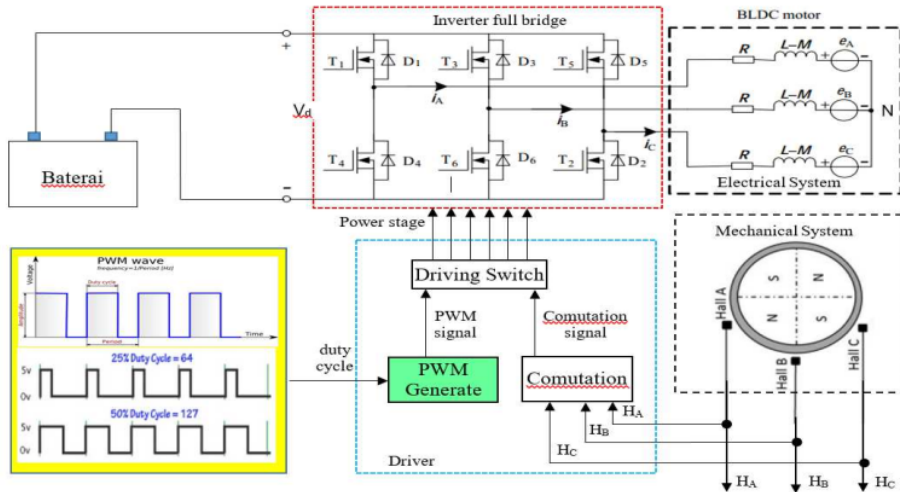

Fig. 4. BLDC motor driver [11].

sent with a duty cycle of 25% and 50%. The duty cycle in PWM can be expressed as follows: [10]

$$D = \frac{T_{on}}{T_{on} + T_{off}} \times 100\% \quad (1)$$

Based on (1) that the change in duty cycle changed the output voltage as follows: [11]

$$V_{out} = D \times V_{dc} \quad (2)$$

with D is duty cycle, T_{on} is high pulse time, T_{off} is low pulsetime, V_{out} is output voltage, and V_{dc} is input DC voltage.

III. THE TECHNIQUE OF DIGITAL PWM

PWM is a technique to get an analog signal from a digital device. PWM can be generated analogously using an op-amp IC or digitally using a microcontroller. The digital PWM generator is affected by the PWM resolution (the number of variations in the value changes in the PWM), for example, the PWM has a resolution of 8 bits, meaning that this PWM has a variation value of 256 (0-225) which represents a 0% to 100% duty cycle.

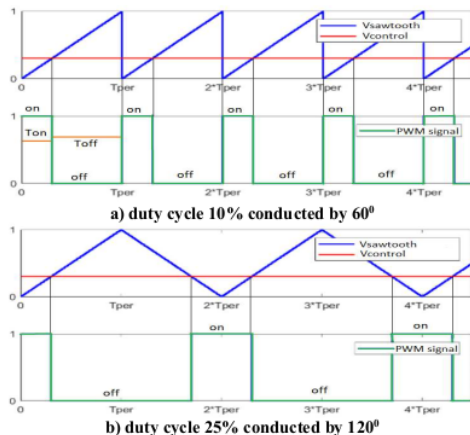

Fig. 5. PWM signal generator [10].

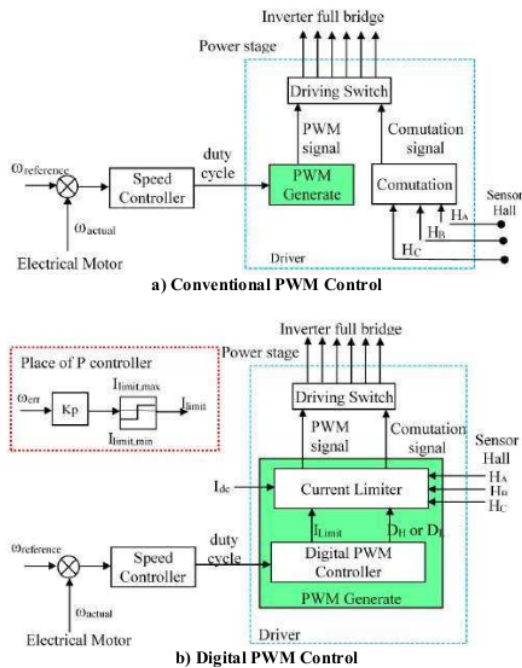

Fig. 6. PWM technique.

The PWM signal generated can be seen in Fig. 5, PWM signal is produced by comparing the voltage control signal ($V_{control}$) in a DC signal with the sawtooth signal ($V_{sawtooth}$) in a triangular signal [10]. If the voltage of the control signal is greater than the sawtooth signal, then the switch is turned on for current conduction, and if the voltage of the control signal is less than the sawtooth signal, then the switch is turned off. The difference in duty ratio can be achieved by varying the amplitude of the control signal. The average voltage applied to the stator winding can be changed by modulating the switch duty cycle within the switching interval time. The DC voltage is kept constant while the

current in the stator winding is determined at a low frequency at the inverter output voltage so that the output current becomes small. Furthermore, the output voltage switches only one of the two switches or switching both the switches. Therefore, PWM strategies can be obtained [11].

The paper proposed an advanced digital PWM control that treats BLDC motor drives like a digital system in Fig. 6b, which is a modification of the conventional PWM control in Fig. 6a. PWM systems may only operate in a low duty (DL) or high duty (DH). Motor speed control is achieved by alternating between low duty and high duty which built advance digital PWM control and BLDC motor drive design simpler. The concept of the operate digital PWM for speed control, including: i) if the actual motor speed is less than the reference speed, and if the motor current is less than the limiting current then the duty high condition (DH), ii) if the actual motor speed is greater than the reference speed and if the motor current is greater than the limiting current, then the condition is low duty (DL), and iii) if the motor current exceeds the limiting current then perform a skip state (zero duty).

The PWM control has no built-in current, so a current limiter must be specified. A proportional control provides a reference current limit. The current is always kept within the maximum and minimum limits ($I_{limit} = 1.5$ times the rated motor current). The minimum value of I_{limit} decides the steady state error and defined as the ratio of a percentage (1%) of the rated torque to the torque constant. The value of the proportional constant K_p is calculated as shown below

$$K_p = \frac{2 I_{limit,max}}{\Delta\omega} \quad (3)$$

with a desired speed ripple ($\Delta\omega = |\omega_{err} \times 2|$) and ω_{err} is speed error.

IV. EXPERIMENTAL SETUP AND DISCUSSION

An experimental setup was built for the implementation and validation of the system with simulation on the testbed as shown in Fig. 7. The testbed consists of a 350W/36V BLDC motor, driver (Arduino Nano and gate driver module), 3 phase inverter (IGBT), current and voltage sensor module, lithium-ion battery (36V/20AH), throttle (setting point), on/off switch and PC (display and store data in real-time). For experimental purposes, a sampling time (T_s) of 0.2ms is determined, and the measurement data is obtained in real-time and stored on a PC while the BLDC motor is rotating. The data obtained from the sensor are in the form of phase current and phase voltage, while the PWM duty cycle data and hall signal are obtained in the form of logic values from Arduino Nano.

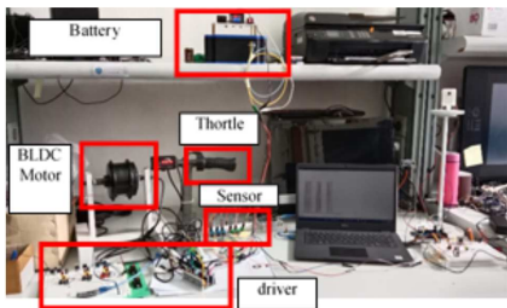
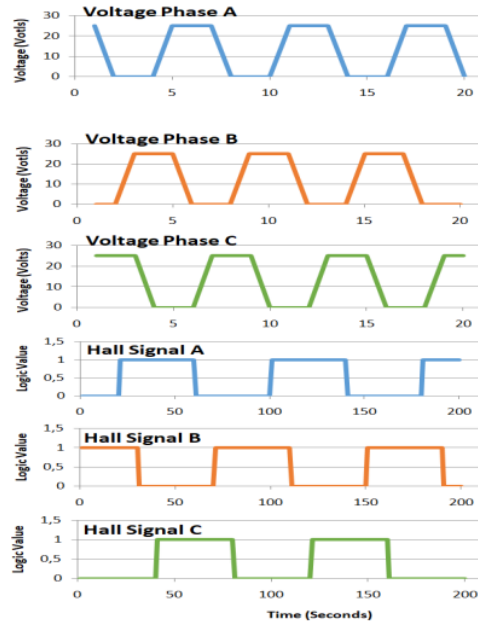

Fig. 7. Testbed.



Based on the driver design in Fig. 6. To see the commutation process running sequentially, a driving switch data is needed in the form of a signal from the driver (Arduino Nano) which contains a six-steps cycle based on hall signal variations. The six-steps cycle will give the command gate switch in the inverter where the voltage will be applied. In the experiment, the BLDC motor is given an input voltage of 25VDC so that the motor can work at a speed of 210 rpm. The measure results of the phase voltage and hall signal can be seen in Fig. 8. It can be seen that the phase voltage and hall signal response work sequentially, therefore the commutation process runs well.

The motor speed reference is set digitally by changing the throttle as a set point by giving the valve value from 0% (idle) to 100% (full). Motor speed control using the digital PWM method may only operate in a low duty (DL) or high duty (DH). Speed control is achieved by alternating between low duty and high duty. In the experiment, given the reference of the motor speed as shown in Fig. 9b (green line), the motor speed varies from 0-300 rpm. Thus it can be seen how the PWM digital signal works as shown in Fig. 9a., for example, while the motor speed reaches 75 rpm for 10 seconds in Fig. 9b., DH and DL obtained 25% and 75%, respectively. This value lasts as long as the speed is constant at 75 rpm, and the PWM signal can be seen in Fig. 9a. (red line). Likewise, for the motor speed reaching 200 rpm in Fig. 9b, the DH (67%) and DL (33%), and the PWM signal can be seen in Fig. 9a. (blue line). The DH and DL values are in the form of logical values which are output from Arduino. The combination of DH and DL provides information for the driving switch in determining the gate switch to drain the voltage.

The PWM signal is also controlled using a speed error which is the difference in the ratio of the actual speed to the speed reference for determining the PWM duty cycle. The speed error is corrected by a proportional gain calculated in real-time from eq. (3) and how it works as shown in Fig. 6b. A proportional gain (K_p) is then multiplied by the current limit

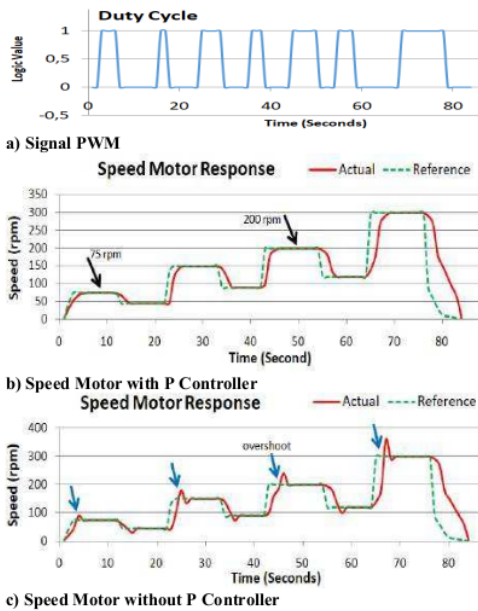

Fig. 9. Duty cycle and speed motor response.

value. The current limit is the sensing of DC link current and keeping it minimum or maximum current limit when the motor is sped up from zero speed or speed down from max to zero speed. If the DC link current value is over the limit, it will automatically set the duty cycle value to zero.

In the experiment, a comparison of the response for the speed motor is carried out by giving the same speed response based on without/with proportional gain integrated into the digital PWM control. As seen in Fig. 9b and Fig 9c, the motor speed response without proportional gain has a slight overshoot before reaching steady-state, while the motor speed response with proportional gain can eliminate the overshoot. Thus proportional control is an important thing in digital PWM techniques, because of the current limiting so that there is no process disturbance in the drive system which gives rise to overshoot. Both responses have different settling times in reaching a steady state. As can be seen, the actual speed (red line) takes 2 seconds (system with proportional control) and 3 seconds (system without proportional gain) to reach the speed reference (green line). There is a difference in settling time of about 0.1 seconds. However, the system still has a good response for speed and motor torque.

V. CONCLUSION

In general, BLDC motors are three phase motors, but in performance not all phase voltages are electrified like three phase motors in general. The phase voltages of BLDC motors must be arranged sequentially and regularly, so the commutation process is an important in design BLDC motor driver. Therefore, the commutation process can run simultaneously and continuously. In addition, the important the performance of the BLDC motor is the motor speed control. The motor speed control conducted by generating

PWM. The technique of the PWM generate has a conventional and a digital PWM. The paper presents the technique of the digital PWM control that may only operate in a low duty (DL) or high duty (DH). Speed motor control is achieved based on the variation of a high duty, low duty or a skip state based on the speed error and the actual motor current. In addition, the proportional control provides a reference current limit as an advance digital PWM control. All processes of commutation and generating digital PWM is integrated in the driver (Arduino Nano).

To see the best response system, a comparison of digital PWM control designs for with/without proportional control have been carried out. In order to obtain a fair comparison, both designs were given the same speed response and the same sampling of data for 80-100 seconds with a sampling time of about 0.2 milliseconds. Based on the experimental results, it found that the digital PWM control design with proportional control can eliminate the process disturbance signal, gives a good response, and has a smaller settling time than the PWM control digital design without proportional control. The digital PWM with proportional control (namely advance control) that integrated in the microcontroller has the potential to be implemented in BLDC motor drives for electric vehicles.

REFERENCES

- [1]. Y. Kiran and P. S. Puttaswamy, "A Review of Brushless Motor Control Techniques," *International Journal of Advanced Research in Electrical, Electronics and Instrumentation Engineering*, pp. 10963-10971, 2013.
- [2]. T. S. Flui, K. P. Basu and V. Subbiah, "Permanent Magnet Brushless Motor Control," in *National Power and Energy Conference (PECoil)*, Bangi, Malaysia, 2003.
- [3]. R. Krishnan, *Electric Motor Drives: Modeling, Analysis, and Control*. New Jersey: Prentice Hall, Inc, 2001
- [4]. P. Wach, *Dynamics and Control of Electrical Drives*. Berlin Heidelberg: Springer-Verlag, 2011.
- [5]. Y.-H. Yoon, T.-W. Lee, S.-H. Park, B.-K. Lee and C.-Y. Won, "New Approach to Rotor Position Detection and Precision Speed Control of the BLDC Motor," in *32nd Annual Conference on IEEE Industrial Electronics*, Paris, France, 2006.
- [6]. S. L. Tade, R. Sor and S. V. Kinkar, "Digital PWM Techniques and Commutation for Brushless DC Motor Control Applications: Review," *International Journal of Advanced Research in Electrical, Electronics and Instrumentation Engineering*, vol. 5, no. 4, pp. 2519-2524, 2016.
- [7]. Adel A. Obed, Abbas K. Kadhim, "Speed and Current Limiting Control Strategies for BLDC Motor Drive System: A Comparative Study," *International Journal of Advanced Engineering Research and Science*, vol. 5, no. 2, pp. 119-130, 2018.
- [8]. A. Aleksandrov, G. Goranov and P. Hubenov, "ALL Digital PWM Control of a Three-Phase BLDC Motor," *Journal of Engineering Science and Technology Review*, no. Special Issue on Telecommunications, Informatics, Energy and Management, pp. 210-214, 2020.
- [9]. L. Shiyong, T. Lemley and G. Keohane, "A comparison study of the commutation methods for the three-phase permanent magnet brushless dc motor," in *Electrical Manufacturing Technical Conference: Electrical Manufacturing and Coil Winding Expo, EMCWA*, 2009.
- [10]. E. Mohan, *Power Electronics: Converter, Application and design*. Singapore: John Wiley & Sons, 1995.
- [11]. R. Ristiana, A. Syaichu-Rohman, A. Purwadi and C. Machbub, "Integrated battery-electric vehicle model and its optimal speed control application," in *3rd International Conference on Control, Automation and Robotics (ICCAR)* (pp. 588-592), Nagoya, Japan, 2017.
- [12]. W. Peng, "Accurate Circuits Model for Predicting The Performance of Lead Acid AGM Batteries," Theses University of Nevada, 2011

Conferences > 2022 8th International Confer...

Advance BLDC Motor Drive Control for Electric Vehicles

Publisher: IEEE



Cite This

Rina Ristiana ; Sunarto Kaleg ; Rina Mardiaty ; Aam Muharam ; Abdul Hapid ; Alexander Christiantho Budiman ; Sudirja ; Amin All Authors

46
Full
Text Views



Abstract

- Document Sections
- I. Introduction
- II. BLDC Motor Drive
- III. The Technique of Digital PWM
- IV. Experimental Setup and Discussion
- V. Conclusion
- Authors
- Figures
- References

Abstract

Various electric motors have been used as the propulsion system of electric vehicles. This paper proposed advanced BLDC motor drive control with the principle of digital PWM which treats the motor like a digital system. The digital PWM control sets six gate switches on the inverter and selects variations of high duty, low duty, or skip state based on the speed error and the actual motor current. In addition, a proportional control provides a reference current limit. All processes of commutating and generating digital PWM are integrated into the driver. The digital PWM with proportional control can eliminate the process disturbance signal, give a good response, and has a good settling time. It has the potential to be integrated into a motor driver. The BLDC motor drive control with the principle of digital PWM implemented for electric vehicles.

Published In: 2022 8th International Conference on Wireless and Telematics (ICWT)

Date of Conference: 21-22 July 2022 **INSPEC Accession Number:** 22238748
Date Added to IEEE Xplore: 07 November 2022 **DOI:** 10.1109/ICWT56831.2022.9835444
Publisher: IEEE
Conference Location: Yogyakarta, Indonesia

More Like This

- Embedded Electronic Differential System on Two Brushless DC Motor Drives for Electric Vehicle Steering Control
- 2018 International Conference on Embedded Systems and Intelligent Technology & International Conference on Information and Communication Technology for Embedded Systems (ICEST-ICCTES) Published: 2018
- Improved Electric Differential System for Independent Speed Control of Brushless DC Motors Driven Electric Vehicles
- 2021 7th International Conference on Control, Instrumentation and Automation (ICCIA) Published: 2021

REPUTASI JURNAL / PROSIDING

Jurnal / Prosiding

Indeksasi ini hanya memuat **Jurnal ilmiah terindeks global bereputasi tinggi, Jurnal ilmiah terindeks global bereputasi menengah, Jurnal ilmiah terindeks global bereputasi, Jurnal ilmiah terindeks lainnya, dan Prosiding ilmiah terindeks global bereputasi**

Data terbaru yang ada di epeneliti adalah data tahun **2021**, indeksasi setelah tahun tersebut mengikuti **indeksasi pada tahun 2021**

i Tahun Terbit

Nama	Tahun	Reputasi	ISSN	E-ISSN	Penerbit
2021 7TH INTERNATIONAL CONFERENCE ON WIRELESS AND TELEMATICS (ICWT)	2021	Prosiding Terindeks Global Bereputasi			IEEE

rr4

ORIGINALITY REPORT

24%

SIMILARITY INDEX

15%

INTERNET SOURCES

17%

PUBLICATIONS

7%

STUDENT PAPERS

MATCH ALL SOURCES (ONLY SELECTED SOURCE PRINTED)

3%

★ www.coursehero.com

Internet Source

Exclude quotes Off

Exclude matches Off

Exclude bibliography Off